

zeagle®

SYSTEMS, INC.

The **Razor**



Regulator/Valve, Service Manual

For Zeagle RaZor 1st and Envoy 2nd Stage Scuba Regulators and Filler Whip
Manual p/n 347-3005, Copyright 2007

RaZor 1st Stage Parts

ITEM # PART # DESCRIPTION.....

1	175-1630	Label
2	341-FB02-CL	Cap (regulator)
3*	160-0022-N7	O-ring (large end of piston)
4	341-FB04-CD	Piston
5*	160-0008-N7	O-ring (small end of piston)
6*	341-FB06-GA	Seat (for piston)
7	341-FB07-VH	Spring (main)
8	341-FB08-SA	Shim
9	341-0127-CD	LP Port Plug (includes O-ring)
10*	160-0011-N7	O-ring (for LP hose & port plugs)
11	341-FB16-CD	Burst Plug
12	341-FB15-ZA	Burst Disc
13	341-FB14-ZA	Gasket (copper)
14	341-FB09-CL	Body
15*	341-0139-BA	Conical Filter
16	341-FB11-AA	Dip Tube Assembly
17*	160-0214-N9	O-ring (for neck of cylinder)
18*	160-0012-N9	O-ring (for QD Fitting, Bonnet Nut & HP Port Plug)
19	341-0128-CD	HP Port Plug (includes O-ring)
20	341-FB24-CA	Plug Assembly
21	341-FB25-CD	Stem
22*	341-FB26-GA	Seal
23	341-FB27-CD	Bonnet Nut
24	341-FB28-GA	Washer
25	341-FB29-CL	Handwheel
26	341-FB30-VH	Spring (for Handwheel)
27	341-FB31-CD	Nut
28	341-FB17-VH	Spring (for check valve)
29	341-FB18-CD	Plug (check valve)
30*	160-0004-L9	O-ring (on check valve)
31	341-FB21-CD	Quick Disconnect (male)
32*	160-0013-N9	O-ring (for Cap)
33	341-FB23-SA	Cap (fill)
34	341-FA10-CL	Filling Adapter
35	160-0014-N9	O-ring (for face of filling adapter)

* An asterisk next to the Item Number means that part is included in the Standard Service Kit. The Service Kit Part # for the 1st Stage is 345-1001. The 2nd Stage Service Kit Part # for the Envoy 2nd stage used with the RaZor is 345-2000.

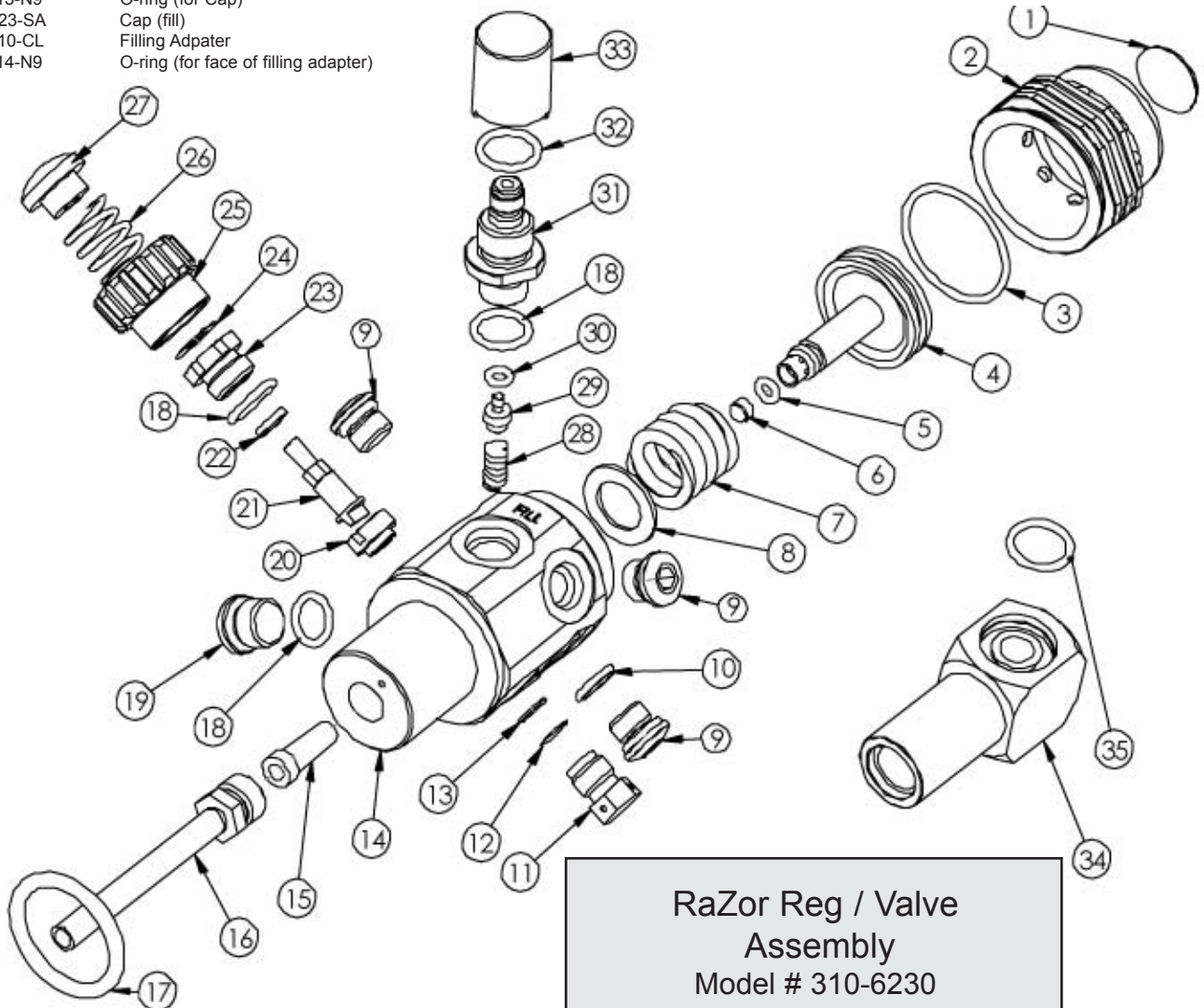

**RaZor Reg / Valve
Assembly
Model # 310-6230**

TABLE OF CONTENTS

- 1.0 Introduction
- 2.0 Specifications
 - 2.1 Torque Specifications
 - 2.2 Model Numbers
- 3.0 O-rings Reference Chart (First Stage)
- 4.0 First Stage Procedures
 - 4.1 Tools Required for First Stage Servicing
 - 4.2 Disassembly of the RaZor First Stage
 - 4.3 Cleaning and Inspection of the First Stage
 - 4.4 Preliminary Assembly of the First Stage
 - 4.5 Set-up and Testing of the First Stage
- 5.0 Envoy Second Stage Service Procedures
 - 5.1 Tools Required for Second Stage Servicing
 - 5.2 Disassembly of the Second Stage
 - 5.3 Cleaning and Inspection of the Second Stage
 - 5.4 Preliminary Assembly of the Second Stage
 - 5.5 Set-up of the Second Stage
 - 5.6 Final Assembly of the Second Stage
 - 5.7 Testing of the Second Stage
- 6.0 Helpful Hints
 - 6.1 Troubleshooting
 - 6.2 Parts Cleaning Recommendations
 - 6.3 Commonly Used Cleaning Solutions
 - 6.4 Handling Tips
- 7.0 Warranty and Maintenance Information
 - 7.1 Proper Procedure for Warranty Paperwork
 - 7.2 Scheduled Maintenance
 - 7.3 Order Form (sample)
 - 7.4 O-rings Reference Chart (Second Stage)

Before You Begin

Read these instructions completely before you begin servicing the regulator or filling whip. These instructions are intended for people who have been AUTHORIZED by Zeagle to repair Zeagle Scuba equipment. If you are not so authorized - STOP.

FIRST STAGE

The letter at the beginning of the serial number on the first stage indicates the model of that first stage. For example, if the serial number begins with "A" it is a DS-V non-swivel first stage (e.g. A001324). "E" is a RaZor (Valve/Regulator) first stage, "G" is a ReZort first stage and "F" is a Flathead VI first stage. For further information, contact Zeagle.

1.0 INTRODUCTION

1.0.1 The procedures in this manual apply to the Zeagle RaZor Valve/Regulator, the Envoy type 2nd stage that comes attached to it, and the Filling Whip. Refer to the exploded views as you read the service section of the manual. The Item Numbers referred to in the service section are those seen in the corresponding exploded view



! WARNING !

NEVER tighten the hose fitting to the first stage with more than 40 in. lbs. (4.5 Nm) of torque. The inlet hose fitting will be weakened by over tightening. Failure to heed this warning may result in serious injury or death.

NOTE: All Zeagle Scuba Regulators have service kits available which contain the parts which must be changed at every annual service no matter what their condition. The standard annual service kit part numbers are shown in the parts list. All other parts not contained in these kits must be inspected by the technician and changed if necessary. Parts will be handled under warranty, only if they have failed due to problems with material or workmanship.



! WARNING !

Zeagle Scuba Regulators are manufactured using materials suitable for use with oxygen enriched gases (i.e. Nitrox, etc.) providing the oxygen content does not exceed 40%. Equipment intended for enriched air (Nitrox) use, must not be used with regular compressed breathing air or other gases. Regulators intended for enriched air use, can be serviced only by technicians trained by one of the major oxygen enriched air training agencies. Failure to heed this warning may result in serious injury or death.

1.0.2 This manual gives breakdowns of regulator parts, equipment specifications, servicing instructions, troubleshooting recommendations, and guidelines for proper care of Zeagle regulators. This manual is intended for use only by persons specially trained and authorized to service Zeagle Scuba equipment.

1.0.3 Anyone attempting to service or repair Zeagle Scuba regulators must have a thorough understanding of the principles of operation of scuba regulators and valves, as well as the appropriate mechanical ability. The technician must be properly trained in the safe use of compressed air and the various tools and cleaning solutions involved in the procedures outlined in this manual.

1.0.4 The best source for current part numbers for any of the parts listed in this manual is your current parts and price list from Zeagle.

1.0.5 Zeagle conducts seminars on a regular basis to train technicians in proper service and repair procedures for all current Zeagle regulators. In addition, all Zeagle dealers and their staff members are encouraged to attend the seminars to gain an in-depth understanding of the construction, special features and operation of Zeagle regulators. For information on the dates and locations of upcoming Zeagle service seminars near you, contact Zeagle or a Zeagle Sales Representative. Service Videos in various formats (VHS, CD, DVD, etc.) are also available.

NOTE: You must be authorized by Zeagle to work on Zeagle Scuba equipment. You can obtain proper authorization by attending all appropriate seminars given in your area. This is the only way you can become an authorized Zeagle technician.

1.0.6 If you have any questions, or need more information, contact your Zeagle Scuba Sales Representative or Zeagle Customer Service. You can e-mail you technical questions to tech@zeagle.com

2.0 SPECIFICATIONS

Zeagle RaZor

AIR FLOW 33 cu. ft. (935 liters/min). @ 1 atmosphere
 INHALATION RESISTANCE ... 0.9" -2.0" (2.3 - 5.08 cm) w.c. @ 1 atmosphere
 EXHALATION RESISTANCE .. 0.6" (1.52 cm) w.c. max. @ 1 atm.
 RECOMMENDED LUBRICANT LTI Christo-Lube 111®

A. FIRST STAGE REGULATOR/VALVE COMBINATION

TYPE Tank Valve with Unbalanced Flow-by Piston Regulator Combined

WEIGHT 1.54 lb. (.69 kg)
 INTERSTAGE PRESSURE 120-140 psi (8.3-9.7 bar) @ 3000 psi inlet (207 bar)
 # LOW PRESSURE PORTS 4 (3/8"-24 UNF)
 # HIGH PRESSURE PORTS ... 1 (7/16"-20 UNF)
 # FILL PORTS 1 (7/16"-20 UNF)

MATERIALS Body ----- CDA-360 Brass
 O-rings ----- Buna-N
 Seat ----- Advanced Polymer

B. SECOND STAGE REGULATOR (Envoy)

TYPE Downstream valve, balanced diaphragm.
 Diver Adjustable Dive / Pre-Dive Venturi. Lever and Technician-Externally-Adjustable Resistance Control Knob.

WEIGHT..... .4 lb. (.18 kg) (w/o hose)
 HOSE LENGTH 48 in. (1.23 m)(as equipped on Rapid Diver BCD)
 MATERIALS Cover ----- Flexible Thermoplastic
 Case ----- Rigid Thermoplastic
 Poppet Seat ---- Advanced Elastomer
 O-rings - Buna-N
 Diaphragm ----- Elastomeric Polymer
 Exhaust Valve-Thermoplastic Elastomer
 Mouthpiece ---- Silicone

2.1 Torque Specifications:

Description	Item #	Torque
RaZor into Tank	--	20-30 ft/lbs (27-41 Nm)
Cap	2	2-3 ft/lb (3-4 Nm)
Valve Bonnet Nut	23	2-3 ft/lb (3-4 Nm)
Burst Plug	11	50-55 in/lb (5.6-6.2 Nm)
Dip Tube	16	2-3 ft/lb (3-4 Nm)
HP Balance Plug	35	2-3 ft/lb (3-4 Nm) (with 1/4" Allen wrench)
QD Fill Probe	31	2-3 ft/lb (3-4 Nm)
Port Plugs	9, 19	2-3 ft/lb (3-4 Nm) (with 5/32" Allen wrench)
Hose inlet end	30	2-3 ft/lb (3-4 Nm)
Hose outlet end	30	2-3 ft/lb (3-4 Nm)
2nd Stage Nut	7	1-2 ft/lb (2-3 Nm)

2.2 Zeagle Scuba Regulator Model Numbers:

Model #	Description
350-1110	Flathead-VI Yoke 1st stage, with ZX 2nd Stage - 30" Hose
350-1121	Flathead-VI DIN 1st stage, with ZX 2nd Stage - 30" Hose + DIN to Yoke Converter
350-1210	Flathead-XP Yoke 1st stage, with ZX 2nd Stage - 30" Hose
350-1221	Flathead-XP DIN 1st stage, with ZX 2nd Stage - 30" Hose + DIN to Yoke Converter
350-2110	50-D (swivel turret), Yoke 1st stage with ZX 2nd Stage - 30" Hose
350-2121	50-D DIN 1st stage, with ZX 2nd Stage - 30" Hose + DIN to Yoke Converter
350-3110	Envoy Yoke 1st stage with Envoy 2nd Stage - 30" Hose
350-3121	Envoy DIN 1st stage, with Envoy 2nd Stage - 30" Hose + DIN to Yoke Converter
350-4110	DS-V Yoke 1st stage with ZX 2nd Stage - 30" Hose
350-4121	DS-V DIN 1st stage with ZX 2nd Stage - 30" Hose + DIN to Yoke Converter
350-5210	Envoy Deluxe Yoke 1st stage with Envoy 2nd Stage - 30" Hose
350-5221	Envoy Deluxe DIN 1st stage, Envoy 2nd Stage-30" Hose + DIN to Yoke Converter
350-6230	RaZor, Valve/Reg 1st stage with Envoy 2nd Stage - 44" Hose
350-7210	ReZort, Yoke 1st stage with Envoy 2nd Stage - 30" Hose
350-7221	ReZort, DIN 1st stage with Envoy 2nd Stage - 30" Hose + DIN to Yoke Converter
320-1110	2nd stage only, ZX Octopus 2nd Stage, with yellow cover - 36" hose
320-1115	2nd stage only, ZX 2nd Stage, with gray cover - 30" hose
320-3115	2nd stage only, Envoy 2nd Stage, with gray cover - 30" hose
320-3110	2nd stage only, Envoy Octopus 2nd Stage, with yellow cover - 36" hose
310-1110	1st stage only, Flathead-VI Yoke
310-1120	1st stage only, Flathead-VI DIN
310-2110	1st stage only, 50-D (swivel turret), Yoke
310-2120	1st stage only, 50-D (swivel turret), DIN
310-4110	1st stage only, DS-V (non-swivel), Yoke
310-4120	1st stage only, DS-V (non-swivel), DIN
310-3210	1st stage only, Envoy, Yoke
310-3220	1st stage only, Envoy, DIN
310-5210	1st stage only, ReZort, Yoke
310-5220	1st stage only, ReZort, DIN
310-6230	1st stage only, RaZor, Tank Valve / Regulator Combination
330-0001	DIN to Yoke Converter (allows a DIN equipped regulator to be mounted on a Yoke Valve with no tools.)

1st Stage O- Rings (included in Kit) # 345-1001 for RaZor Valve/Regulator Model # 310-6230

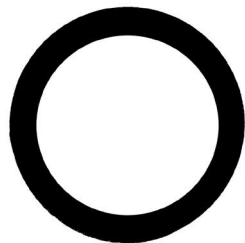

160-0214-N9 (17) to seal base to cylinder

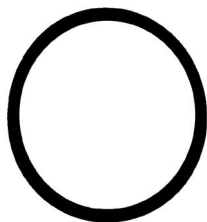

160-0022-N7 (3) for large end of piston (4)



160-0014-N9 (35) for Filling Adapter (35)



160-0013-N9 (32) for QD cap (2)



160-0012-N9 (18) for bonnet nut (23), QD probe (31)



160-0011-N7 (10) for LP ports (9)



160-0008-N7 (5) for small end of piston (4)



160-0004-L9 (30) (white urethane) for check valve (29)

4.0 SERVICE PROCEDURES FOR THE ZEAGLE RaZor, Valve/Regulator Combination

4.0.1 Before you begin disassembly of the regulator, test the first and second stages for output pressures and leakage. Pre-testing in this way will help the technician to pinpoint any specific problems requiring repair.

4.0.2 The work area must be clean and well lighted, with clean compressed air available to blow sand and dirt from parts.

4.1 TOOLS & ITEMS REQUIRED FOR RaZor 1st STAGE SERVICING

- 5/32" Allen wrench (p/n 347-0532)
- 3/16" Allen wrench (p/n 347-0316)
- 1/16" drill bit
- 6" or 8" good quality adjustable wrenches for hose connections.
- 10" or 15" good quality adjustable wrenches for the Cap and Body
- 1st Stage Annual Service Kit p/n 345-1001
- Clean Shop Rags
- LTI Christo-Lube 111® (p/n 347-.0111), or Dow-Corning 111® Silicone Grease
- Service Video Tape for this regulator (p/n 347-0103) or Service CD ROM (p/n 347-0103C) or DVD (p/n 347-0103D)
- Intermediate Pressure Testing Gauge

4.2 DISASSEMBLY OF THE RaZor FIRST STAGE FOR OVERHAUL

To view all of the parts used in the RaZor first stage, look at the inside front cover of this manual. The bracketed numbers in the text refer to the corresponding circled item numbers on the exploded view drawing.

4.2.1 CAREFULLY bleed ALL of the air from the cylinder that the RaZor 1st stage is installed in by opening the Valve (25) and depressing the Purge Button on the 2nd stage until the reading on the submersible pressure gauge is between 50 and 100 psi. Use the 6" adjustable wrench to carefully turn the Burst Plug (11) counter-clockwise just until you hear the final pressure being relieved. Do not remove the Burst Plug (11) at this time. Remove a low pressure port plug to insure that all cylinder pressure is relieved as the cylinder warms back up. The purpose of this exercise is to loosen the Burst Disc (12) for later removal.

4.2.2 Use 6" or 8" adjustable wrenches to disconnect all hoses from the first stage. Pull back the hose protector from the inlet end of the hose. Inspect the hoses for wear. Pay particular attention to the area where the metal ferrules meet the rubber hose material. Remove and discard the O-rings from each end of the hose. Clean, rinse, and blow-dry the interior bores of the hoses. Replace the hoses if necessary.

Note: Hose Protectors are easier to slide back from the 1st stage end of the hose if they are twisted and pulled when the hose is still installed in the 1st stage. If a hose protector is particularly difficult to pull back, try removing the hose and soaking the hose protector end in hot water to soften it up. Temporarily reinstall the hose and try pulling and twisting the hose protector again.

4.2.3 With the Razor Valve/Regulator still installed tightly in the cylinder (AND ALL AIR BLED FROM THE CYLINDER), use a 10" or 15" adjustable wrench to loosen (not remove) the Cap (2) from the Body (14).

4.2.4 Use a 3/16" Allen wrench to remove all port plugs from the body. Discard the port plug O-rings. (10, 18)

4.2.5 Use the 6" adjustable wrench to loosen and remove the male Quick Disconnect probe (31) from the body. When removing probe, be careful not to lose the Spring (28) or Check Valve Plug (29). Discard the Probe and Plug O-rings (18, 30, 32)

4.2.6 Turn the Valve Handwheel (25) so the Valve is about 1/2 way between open and closed. Use a 5/32" Allen wrench to remove the Nut (27) from the Valve. Remove the Spring (26), Handwheel (25), and Washer (24) from the Stem (21).

4.2.7 Use the 6" adjustable wrench too loosen and remove the Bonnet Nut (23). Remove the Stem (21) from the Bonnet Nut and use it as a tool to turn the Plug Assembly (20) out of the body. (See Photo 1)



Plug Assembly (20) removal using Stem (25) as a tool.

Photo 1

If the Valve was not turned 1/2 way between open and closed as described in step 4.2.6, you may need to install the Handwheel (25) temporarily back on the Stem to turn the Plug Assembly out with more force.

4.2.8 Remove and discard the O-ring (18) and Seal (22) from the Bonnet Nut (23).

4.2.9 Unscrew the Burst Plug (11) that was previously loosened in step 4.2.1. Tip the tank and body so that the Burst Disc (12) and Gasket (13) fall out. If the Gasket (13) does not fall out when the body is tipped, you may need to pry it out with a soft brass pick. Be EXTREMELY careful and do not scratch the surface under the gasket, since a scratch on the body at the gasket area will create a leak. The gasket can be reused once or twice. If you are going to reuse it and it does not fall out easily, leave it in place when the reg is cleaned. Check that it is still in place during assembly.

4.2.10 At this point, all of the ports on the body should be empty.

4.2.11 Hold the cylinder with a firm strap band or mount it in a tank vise. Use normal precautions, so that the surface of the cylinder is not marred or damaged. Use a good 10" or 15" adjustable wrench to grip the wrench flats on the RaZor body tightly. You can also use an HP Port Wrench. Apply a counter-clockwise force to remove the RaZor from the cylinder. (See Photo 2)



Removing the RaZor from the Cylinder

Photo 2

4.2.12 Remove the valve thread O-ring (17) from the RaZor and discard it.

4.2.13 Use a 6" adjustable wrench to remove the Dip Tube (16) from the Body (14). Remove and discard the Filter (15) from the Body.

4.2.14 Remove the Cap (2) from the Body (14). It should be hand-tight from step 4.2.3. Remove any Spacer(s) (8), the Spring (7) and the Piston (4) from the Cap. Remove and discard the O-rings (3, 5) from the piston. Whenever possible, try to remove the O-rings by pinching them with the fingers and rolling them out of the groove.

! WARNING ! If a sharp pick is used to remove the O-rings, it should be made from soft brass, not steel. ANY scratches left in the groove when removing O-rings will cause leaks (bubbling out of the Cap ambient pressure ports) and the piston will have to be replaced to stop these leaks.



4.2.13 Remove the Seat (6) from the Piston (4) by pushing it out with a 1/16" drill bit. Place one end of the drill bit on a flat hard surface. Lower the large end of the Piston over the drill bit until the flat end of the drill bit rests against the back side of the Seat. Push the Piston firmly down straight on the drill bit, until the seat is pushed out of the piston. Discard the old Seat. See Photo # 3.

Photo 3

4.3 Cleaning and Inspection of the 1st Stage

4.3.1 Clean all metal parts of the first stage in an ultrasonic cleaner or cleaning solution. See Section 6.3 for recommendations on cleaning solutions. Remove the O-rings before cleaning any metal parts since the soft O-ring material will absorb cleaning energy from the ultrasonic cleaner reducing its effectiveness. If major visible corrosion or deposits exist on parts, use a bristle brush, wooden, or plastic stick to rub the deposits off. Allowing acidic cleaning solutions to do all of the work if deposits are severe, will result in damage to internal chrome plating which will make parts even more susceptible to future corrosion.

4.3.2 Remove the regulator parts from the cleaning solution. Rinse with clean fresh water, then blow internal passageways dry with clean, dry compressed air.

4.3.3 Inspect all O-ring grooves for scratches or wear. If the regulator was leaking air because of scratches or wear, replace the parts. If some corrosion deposits persist, carefully wipe them away with a plastic scrubbing cloth or plastic or wooden dowel. Blow any resulting dust out of the regulator parts.

4.3.4 Closely examine the sealing cones (orifices) in the Body (14) where the valve Plug Assembly (20) and where the Seat (6) of the Piston (4) seal.

4.4 PRELIMINARY ASSEMBLY OF THE FIRST STAGE

4.4.1 To determine the identity of each O-ring in the Service Kit, remove them from the bag and use the O-ring Identification Chart on the front page of this manual. Lay each O-ring over its corresponding picture on the page and read the description. Before installing new O-rings into the regulator, lightly lubricate the O-rings with LTI Christo-Lube 111® (for enriched air regulators), or Dow-Corning 111® silicone grease. The most effective way to lubricate the kit O-rings is to put them in a small plastic bag with a pea sized amount of grease. Rub the O-rings and grease together in the bag until all the O-rings are coated evenly. Try not to wipe the lubrication off the O-rings when assembling them onto other parts.

4.4.2 Use the Stem (21) to turn the Plug Assembly (20) clockwise in the valve port in the Body (4) until it bottoms.

4.4.3 Install a new lubricated O-ring (18) onto the valve Bonnet Nut (23).

4.4.4 Install a new lubricated Teflon Seal (22) into the Bonnet Nut (23).

4.4.5 Install the Stem (21) into the Bonnet Nut (23).

4.4.6 With the Stem (21) slightly protruding from the Bonnet Nut, insert the Stem's tang into the slot of the Plug Assembly (20). Turn the Bonnet Nut Clock-wise to screw it into the Body (14). NOTE: While screwing the Bonnet Nut into the body, periodically twist the Stem and the Plug Assembly to be sure that they are properly engaged. Tightening the Bonnet Nut down without the tang of the stem engaged in the Plug Assembly can damage the tang on the Stem. Tighten the Bonnet Nut (23) to 2-3 ft/lb (3-4 Nm) of torque.

4.4.7 Lubricate with a small amount of grease and install the Teflon Washer (24) onto the Stem (24).

4.4.8 Install the Handwheel (25) onto the stem.

4.4.9 Install the Spring (26) into the Handwheel.

4.4.10 Install the valve Nut (27) onto the Stem (21). Use a 5/32" Allen wrench to tighten the Nut until the outer edge of the nut is flush with the top edge of the Handwheel (25).

4.4.11 Position the Body (14) so that the port marked "FILL" is facing up. Place the Spring (28) into the FILL port with the wide end of the spring facing down.

4.4.12 Install the O-ring (30) onto the check valve Plug (29). NOTE: This O-ring is quite stiff. A technique for installing the O-ring onto the Plug is to place the new O-ring on a clean flat surface. Grip the Plug with a pair of pliers. Push the Plug stem into the hole of the O-ring until the stem touches the flat surface. See Photo # 4. Push the O-ring the rest of the way into place with the fingers.

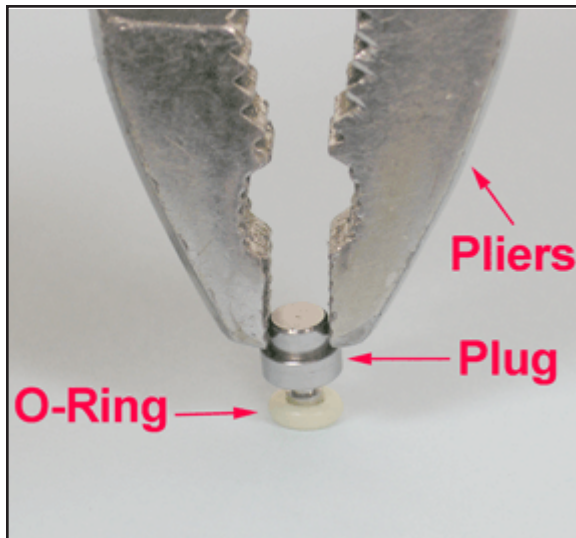

Installing the Plug (29) into the O-ring (30).
(The Kit O-ring may be black)

Photo 4

4.4.13 Place the Plug and white O-ring assembly into the Spring (28) with the O-ring facing up.

4.4.14 Install the O-ring (18) onto the Quick Disconnect (31) over the threads that will screw into the Body.

4.4.15 Install the O-ring (32) onto the Quick Disconnect (31) over the threads that the Cap (33) will screw onto.

 **! WARNING !** The QD Cap O-ring (31) is just slightly larger than the typical HP Port O-ring. Be very careful using the O-ring Chart, to make sure you are selecting the proper O-ring from the Service Kit. Failure to install the proper O-ring will result in premature O-ring failure and leakage.

4.4.16 Install the Quick Disconnect (31) into the "FILL" port over the Spring (28) and Plug (29). Tighten the QD Probe (31) to 2-3 ft/lb (3-4 Nm).

4.4.17 Install the Fill Cap (33) onto the QD Probe (31) hand tight.

4.4.18 Hold the Body (14) so that the Burst Plug Port is facing up. Drop the Burst Gasket (13) into the port first. (Bulge outwards if it is used.) Drop the Burst Disc (12) on top of the gasket. If the Gasket or Disc do not fall properly in place, use something soft like a plastic toothpick to push them into place.

4.4.18 Install the Burst Plug (11) over the Burst Disc. Tighten the Burst Plug to 50-55 in/lb (5.6-6.2 Nm).

4.4.19 Install the Filter (15) into the tank thread end of the body with the narrow end first. Install the Dip Tube Assembly (16) over the Filter. Tighten the Dip Tube with 2-3 ft/lb (3-4 Nm) of torque.

4.4.20 Install the O-ring (17) onto the thread end of the body.

4.4.21 Use the fingertip to spread a film of grease on the inside of the Cap (2) where the large O-ring (3) slides.



Installing the Seat (6) into the Piston (4)

Photo 5

4.4.22 Place the piston Seat (6) on a clean flat surface and press the Piston (4) stem straight over the seat until the new seat is installed into the end of the Piston. See Photo 5.

4.4.23 Install the pre-lubricated (see 4.4.1) O-rings (3, 5) onto the piston. Carefully guide the large end of the Piston into the Cap until it bottoms. Use a gentle rocking motion of necessary to move the Piston into the Cap, but do not cock it at too severe an angle since this may cause the Piston to gouge the sealing surface of the Cap.

4.4.24 Support the Body (14) so that the Cap threaded end is facing up. Use the same number of Shims (8) that were installed in the Spring Cavity when you took the RaZor apart. If there was one Shim, it goes on the Body side of the Spring (7). If there were two Shims, install one at each end of the Spring.

4.4.25 Install the Spring (7) on top of the Shim.

4.4.26 Lubricate the threads on the Cap (2) with grease. Bring the Cap with its Piston (4) installed, over the Spring and Shim sitting in the cavity of the body and screw them together as far as you can by hand.

4.4.27 Install the new O-ring (35) from the Service Kit into the face of the Filling Adapter (35).

4.4.28 Wipe a dab of grease on the first (outward) three male threads on the Regulator. Install the Regulator into its Cylinder hand tight. Mount the cylinder in a secure plastic band tool or tank vise that will not mar the finish on the cylinder. Use a wrench on two wrench flats on the regulator (that do not have Port Plugs or Hoses in them yet) to tighten the regulator into the cylinder with 20-30 ft/lbs (27-41 Nm) of torque.

4.4.29 Use a wrench to snug the Cap (2) onto the body with 1-5 ft/lbs (1.4- 7 Nm) of torque.

4.5 SET-UP AND TESTING THE FIRST STAGE

Note: The RaZor regulator has an unbalanced piston 1st stage. Intermediate pressure will begin in the higher end of the range with high tank pressures and drop as the tank pressure decreases with use. For this reason, the RaZor's intermediate pressure must be tested and set at the highest inlet (cylinder) pressure that the regulator is going to see during use. This is usually 3000-3500 psi (207-241 bar).

4.5.1 Install the normal hoses, fittings and all but one LP Port Plug into the ports of the 1st stage.

4.5.2 In the remaining open port, install an intermediate pressure gauge. Make sure at least one of the ports has a functioning 2nd stage installed or that the intermediate pressure gauge has an Over-Pressure Relief Valve.

4.5.3 Turn the Valve Handwheel (25) on the RaZor clockwise to the OFF position.

4.5.4 Slowly (while observing proper safe filling procedures) fill the cylinder using either the 341-FA10-CL Yoke Fill Adapter supplied with every RaZor, or the 330-6048-AA Filling Whip and Valve Assembly. Remember that for proper set-up, the cylinder must be filled to the full rated pressure. Disconnect the filling whip or adapter when finished.

4.5.5 Listen carefully for any leaks. Immerse the RaZor in water if leaks are suspected but not confirmed. If leaks are found, correct the problem causing the leaks before proceeding.

4.5.6 Position the intermediate pressure gauge so the dial can be seen. See Photo 6.



Checking the Intermediate Pressure with a Gauge

Photo 6

4.5.7 Turn the air on to the regulator section of the RaZor by SLOWLY turning the Handwheel (25) counter-clockwise while listening for any unusual air leaks. If any are heard, turn the air off immediately and determine the source of the leak. If no leaks are found, watch the intermediate pressure gauge reading rise as you continue turning the air on slowly. It should stop before 160 psig (11 bar).

4.5.8 If the pressure gauge continues to rise above 160 psig (11 bar), turn the air supply off immediately and inspect the regulator to determine the cause.

4.5.9 Depress the 2nd stage purge cover fully, then release it several times to clear particles from the regulator, and to work the internal parts into place. To prevent uncontrolled free flows after pushing the purge cover, keep the venturi control lever on the second stage in the “-” (negative position).

4.5.10 The pressure range for Zeagle RaZor Regulators at 3000 psi inlet pressure is 120-150 psi (8.3-10.3 bar). Add Shims (8) in either side of the spring (7) to raise the intermediate pressure. Remove Shims to lower the pressure. The pressure increase per shim is not linear due to the rate of the spring, so no specific increase per spring can be given. Generally, only add a shim if the intermediate pressure (when the cylinder pressure is 3000 psi) is below 120 (8.3 bar). Adding just one shim under these conditions will not push the intermediate pressure above the maximum 160 pressure. Do not aim for a specific pressure within the range, just add or remove shims to get the pressure within the range. The optimal intermediate pressure for Zeagle RaZor regulators is 130 psi (10 bar), but any setting between 120 and 160 psi (8.3-11 bar) at 3000 psi (207 bar) inlet pressure will provide good stable performance.

4.5.11 After reaching the proper pressure setting, push the purge cover on the second stage again several times and watch how the intermediate pressure reading responds. When the purge cover on the second stage is depressed, the intermediate pressure reading will drop. When the purge cover is released the pressure should return immediately to the proper lock-up pressure and stay there.

4.5.12 Let the regulator sit with the tank valve turned on for several minutes. The intermediate pressure reading may rise about 3 psi in the first three seconds after lock-up, but after that it should not rise more than another 4 psi (.3 bar) in five minutes. If it rises more than 4 psi refer to the Trouble-shooting Section 6.1 of this manual.

Note: Never set the output pressure of the first stage above 160 psig (11 bar).

5.0 ENVOY SECOND STAGE SERVICE PROCEDURES

The RaZor regulator comes equipped with a Zeagle Envoy 2nd stage. Procedures covered in this manual section apply to the ENVOY second stage. To access the exploded view of this model open the back cover of this manual. This second stage is used as a primary unit, gray or black purge cover and 30” hose (model assembly number 320-3115) and as an advanced octopus unit, yellow purge cover and 36” hose (model assembly number 320-3110). See the picture on the front page of this manual section to identify this model type. The serial number for this model always starts with “J”. The number can be seen by curling back the mouthpiece and looking at the end of the mouth-tube.

5.1 TOOLS REQUIRED (or suggested) FOR SECOND STAGE SERVICING

- Two good quality 6” or 8” (15 or 20 cm) adjustable wrenches
- Side cutting pliers
- Cover Ring Removal and Purge Dome Alignment Tool (p/n 347-1005)
- 3/16” Allen Wrench (p/n 347-0316)
- 2nd Stage, Inline Adjusting Tool - 3/16” Hex (p/n 347-0002)
- 2nd Stage Annual Service Kit (p/n 345-2000)
- Clean Shop Rags
- Dow-Corning Compound 111® Silicone Grease or LTI Christo-Lube 111® (p/n 347-0111)

- Service Video Tape for this regulator (p/n 347-0103) or Service CD ROM (p/n 347-0103C) or DVD (p/n 347-0103D)

5.2 DISASSEMBLY OF THE SECOND STAGE

 **! WARNING !** NEVER tighten the hose fitting to the first stage with more than 40 in. lbs. (4.5 Nm) of torque. The inlet hose fitting can be weakened by over tightening.

To view the complete parts list of the second stage, open the back cover of this manual.

5.2.1 Use the 6" and 8" adjustable wrenches to loosen the hose nut from the valve tube (21). Remove the hose assembly (30) from the second stage. Inspect the hose assembly for any cuts or cracks, especially on the hose at the metal ferrules. Remove and discard the O-rings from each end of the hose. Clean, rinse, and blow-dry the interior bores of the hoses. Replace the hose assembly if any cuts or cracks are found.

5.2.2 Remove the mouthpiece (12) by cutting the mouthpiece tie (11) with side cutting pliers. Discard the old mouthpiece tie. Examine the condition of the mouthpiece. Pay particular attention to the area on top just behind where the old tie tightened. This is a prime area for small holes to develop. If the mouthpiece is in good condition, it can be reused.

5.2.3 Remove the exhaust tee (13) from the case by pulling it back and off the top edge of the retaining flange on the housing. Note: The exhaust tee can be removed more easily if hot water from a tap is run over and through it for about 1 minute.

5.2.4 Before removing the exhaust valve (14) from the housing (10), bend the valve over as far as it will go from the top, bottom, left, and right sides. If it fails to snap back quickly, and does not lie perfectly flat against the housing exhaust grid, the valve should be replaced. If it does snap back satisfactorily, remove it by pulling it out with your fingers. Inspect the sealing edges. If they appear smooth, and the locking tab on the nipple is good, the valve can be reused.

5.2.5 Unscrew the cover ring (1) from the housing (10).

5.2.6 Remove the diaphragm cover (3) and the diaphragm (4) from the housing (10).

If the cover is difficult to remove you can try several methods to loosen it;

- Heat the 2nd stage body surrounding the Ring by running hot water from a tap over it. When the plastic is hot, it will expand and loosen the threads.

- Rubber pads are available to use in the hand to loosen tight jar lids. These pads will allow you to get a better grip on the Cover Ring (1)

- Zeagle sells a Cover Ring Removal/Purge Cover Aligning Tool. The part number is 347-1005 See photo 7.



Ring Tool p/n 347-1005

Note: Tool may also be black plastic.

Photo 7

One side of the 347-1005 tool is used to engage the notches on the Cover Ring (1). Once the notches are engaged by the tool, it is easy to turn the Cover Ring off of the Housing by turning the tool counter-clockwise. See photo 8.



Photo 8

5.2.7 For future reference, look at the lever (19) at this time. Notice how the pivot end of the lever is held into the valve tube (21) by two plastic flanges on the housing. Note this positioning for re-assembly.

5.2.8 Hold the diaphragm up to a light source. Gently stretch the diaphragm and look for tears or pinholes. If any are found, replace the diaphragm.

5.2.9 Loosen and remove the nut (7) from the valve tube (21)

5.2.10 Remove the plastic bushing (8) from the valve tube.

5.2.11 Remove and discard the O-ring (9) from the valve tube.

5.2.12 Use a 1/4" Allen Wrench to turn the black plastic spring adjust plug (29) fully counter clockwise until it comes to its stop. Do not use an unreasonable force to do this. Stop turning the plug as soon as a resistance is felt.

5.2.13 Depress the lever (19) fully onto the valve tube. Grasp the tab of the venturi control lever (16). While pulling on the venturi control lever, push the valve tube assembly out of the housing (10).

5.2.14 Remove the venturi control lever (16) from the valve tube assembly. Remove and discard the O-ring (15) from the venturi control lever.

5.2.15 Use a 1/4" Allen wrench to turn the spring adjust plug (29) clockwise 1/4" turn. The pin (20) will fall out of the valve tube or can now be easily removed.

5.2.16 Turn the spring adjust plug (29) counter clockwise to remove it from the valve tube. Remove and discard the O-ring (28).

5.2.17 The balancing chamber (26), spring (25) and piston (23) are removed at this time. They will often fall out if the valve tube is tipped on its end. If the piston will not fall out, the lever (19) can be moved through its full arc. If the piston still does not come out a 5/32" (4-5 mm) Allen wrench can be inserted through the male threaded end of the valve tube, through the seat (18) to gently push the piston out.

5.2.18 Remove and discard the O-ring (27) from the outside of the valve tube (21).

5.2.19 The lever (19) should not be removed from the valve tube unnecessarily. However, it can be removed from the valve body by carefully springing out one of the feet and pivoting it over the valve tube body. Do not over-bend the lever legs. Straighten the legs if they are bent outward from parallel.

5.2.20 Remove and discard the seating seal (22) from the piston (23).

5.2.21 Remove and discard the very small O-ring (24) from the piston. This can be done by pinching a section of the O-ring out of the groove with the fingernails. Then flip the O-ring off the end of the piston stem. **DO NOT USE SHARP METAL PICKS!** Metal tools will damage the O-ring groove, which will cause a small continuous second stage leak.

5.2.22 Use a 3/16" Allen wrench or the Zeagle 2nd Stage, Inline Adjusting Tool - 3/16" Hex (p/n 347-0002) to turn the seat (18) counterclockwise enough turns to fully disengage the threads from the valve tube (21).

5.2.23 After the threads are disengaged, remove the seat (18) from the valve tube (21) by pulling and turning counterclockwise at the same time. The seat will usually come out on the end of the Allen wrench. If it will not come out, it can be pushed out with a soft wooden dowel however, care must be taken not to damage the seat if it is pushed out.

5.2.24 Remove and discard the O-ring (17) from the seat.

5.3 CLEANING AND INSPECTION OF THE 2nd STAGE

5.3.1 Rinse all plastic and silicone parts in fresh warm soapy water solution. Rinse with clean warm water and then blow the parts dry with compressed air to remove any sand and dust particles.



! WARNING !

DO NOT use vinegar or other acid solutions on the plastic parts since this will cause the plastic to become brittle!

5.3.2 If necessary because of deposits or corrosion, clean all metal parts of the second stage in an ultrasonic cleaner or cleaning solution. See Section 6.3 for recommendations on cleaning solutions.

5.3.3 Inspect the housing (10) for any cracks or nicks. Look particularly closely at the area where the exhaust valve (14) seals and where the bushing (8) clamps. Replace the housing if any cracks are found.

5.3.4 Inspect the sealing surface on the seat (18) (where the seating seal (22) seals) for any nicks or scratches. Replace the seat (18) if any serious defects are found at the sealing area, or if the threads appear worn out.

5.3.5 Blow all dust and debris out of the orifice with clean compressed air.

5.3.6 Inspect the exhaust valve (14). Look carefully at the base of the barbed nipple where it comes out of the middle of the valve. Look for any tearing at this point. Replace the valve if any tears are found. Replace the valve if nicks or tears are found at the sealing edges of the valve.

5.3.7 During an Annual Overhaul, all parts included in the Annual Service Kit are replaced no matter what the condition of those parts. Carefully examine all other parts of the second stage for signs of deterioration. Replace those parts too where necessary

5.4 PRELIMINARY ASSEMBLY OF THE SECOND STAGE

5.4.1 Ensure that all parts are clean. To determine the identity of each O-ring in the Second Stage Service Kit, remove them from the bag and use the O-ring Identification Chart on the back page of this section. Lay each O-ring over its corresponding picture on the page and read the description.

Before installing new O-rings into the regulator, lightly lubricate the O-rings with Dow-Corning 111® Silicone Grease or LTI Christo-Lube 111® (EXCEPT O-ring (9) that goes over the valve tube (21) male threaded end).

5.4.2 Install the exhaust valve (14) into the case by inserting the nipple into the square hole from the outside of the case. Reach inside the case and pull the nipple firmly with the fingers until you hear or feel it “click” into place. Inspect the exhaust valve to see that it is properly seated. Take care not to get any lubricating grease on the exhaust valve during this procedure.

5.4.3 Install a new O-ring (27) onto the outside of the valve tube (21).

5.4.4 If the lever (19) was removed, carefully re-fit it into the valve tube (21). To orient the lever properly, hold the valve tube with the external threads to the left. Turn the valve tube until you can see the hole where the air exits the valve tube (indicated by the arrow in photo). The lever is inserted so that it hangs down and curves leans to the right. See Photo 9. Work the lever into the valve tube one foot at a time so the lever legs are spread outwards as little as possible.

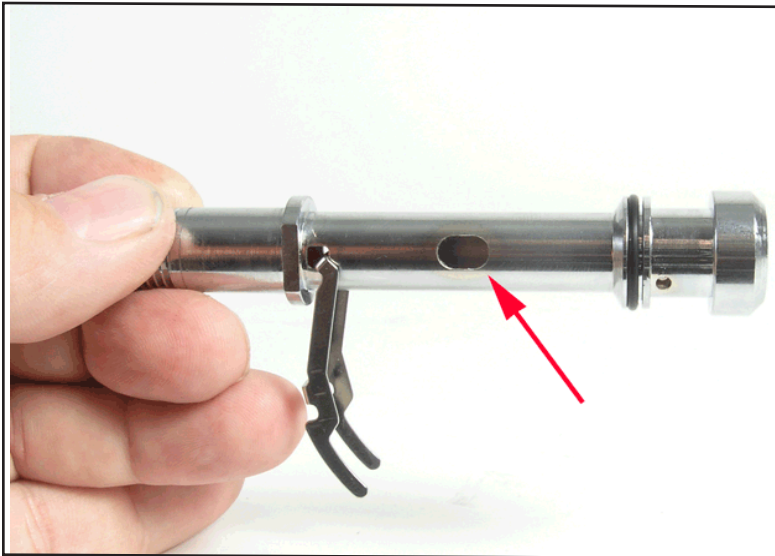

Photo 9

5.4.5 Insert the new seating seal (22) into the white piston (23).

5.4.6 Install the lubricated small O-ring (24) onto the piston tip.

5.4.7 Install the spring (25) onto the piston and the balance cylinder (26) onto the piston to make the shuttle valve assembly.

5.4.8 Insert the shuttle valve assembly you have just assembled, into the valve tube (21) at the end with the raised collar (opposite the external threaded end). See Photo 10.

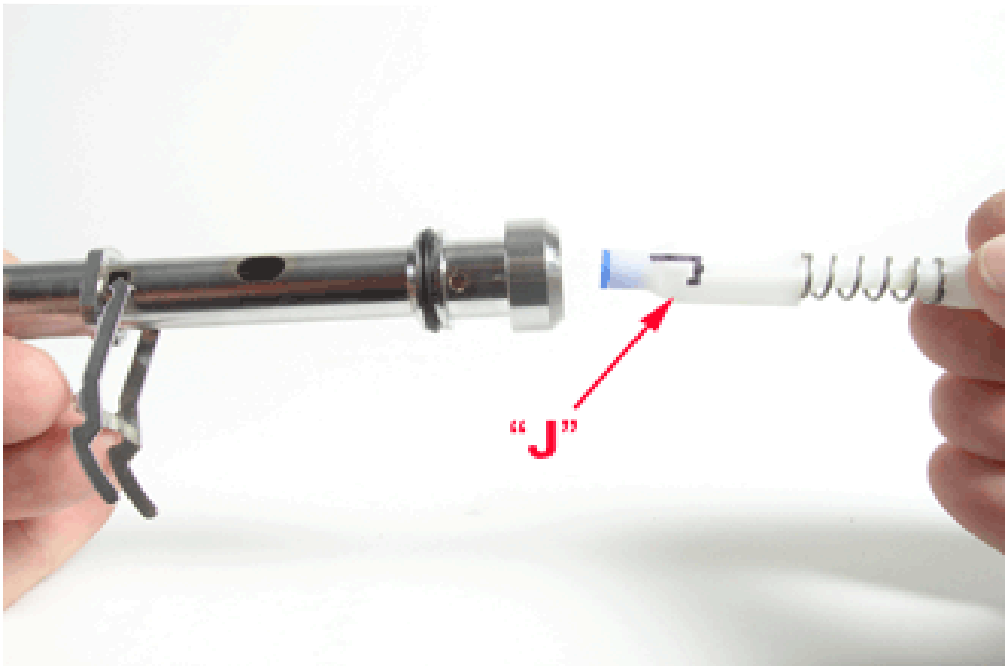

Photo 10

5.4.9 When the shuttle assembly is inserted into the valve tube, it is important that the “L” shaped foot on the piston section engages properly with the lever tabs that extend through the holes in the valve tube. In Photo # 10, the “J” shaped foot has been highlighted with black marker so you can see the “J” clearly. The piston is normally all white.

5.4.10 Insert the shuttle valve assembly as shown in Photo # 10. Push the assembly all of the way into the valve tube. The first thing that might hang up on the tabs of the lever is the black seating seal. Wiggle the lever to get this past the tabs. When the “J” shaped feet get to the lever tabs they will lift the lever inwards as you push the assembly in.

5.4.11 Install a new well lubricated O-ring (28) onto the spring adjuster plug (29).

5.4.12 Insert the spring adjuster plug into the valve tube over the shuttle valve assembly you just installed.

5.4.13 Turn the spring adjuster plug clock-wise until the O-ring and flange have passed the hole where the pin (20) is installed.

5.4.14 Install the pin (20) into the valve tube (21).

5.4.15 Back the spring adjuster plug out counter-clockwise until it tightens against the pin (20), holding it in place.

5.4.16 Install the new O-ring (15) onto the venturi control lever (16).

5.4.17 While holding the tabs in place in the valve tube with two fingers, depress the lever (19) and slide the venturi control lever (16) into place on the valve tube (21).

5.4.18 Install the valve tube assembly into the housing (10). After assembly, make sure that the pivot end of the lever is held into the valve tube (21) by two plastic flanges on the housing just as they did when you took the housing apart (see step 5.2.7).

5.4.19 Install the O-ring (9) over the external threaded end of the valve tube (21).

5.4.20 Install the bushing (8) (flat side facing the body) over the external threaded end of the valve tube.

5.4.21 Install the nut (7) over the external threaded end of the valve tube. Tighten the nut snugly 1-2 ft/lb (2-3 Nm) with a wrench.

5.4.22 Install the new lubricated O-ring (17) onto the seat (18).

5.4.23 Use the 3/16" Allen wrench or the 2nd Stage, Inline Adjusting Tool - 3/16" Hex (p/n 347-0002) to install the seat into the valve tube.

5.4.24 Tighten the seat (18) clockwise with the Allen wrench. It is important that the final adjustment leaves the lever with about 1/8" (3.2 mm) free movement at the end, to allow for the natural wear of the seating seal (22) during the use of the regulator. Adjust the seat (18) in, while moving the end of the lever up and down with the tip of your finger. When the seat is too far out (counter-clockwise) you will feel a firm springiness with no free movement. When the seat is too far in (clockwise) you will feel a great deal of looseness at the end of the lever. You want the seat (18) to be positioned so that you feel the 1/8" (3.2 mm) free play when you move the tip of the lever with your finger. See photo 9.

Inline Adjusting Tool Method:

Install the Zeagle Inline Adjusting tool p/n 347-0002 between the hose and the 2nd stage body. Turn the plastic spring adjuster plug (29) on the regulator all of the way out (counter clockwise). Use the inline tool to just begin to thread the seat (18) into the valve tube. CAREFULLY turn the tank air on just barely enough to let airflow through the regulator. You will hear a hiss of air coming from the second stage. Turn the seat clockwise (toward the seal). As soon as the seat makes contact with the seal, the air will stop flowing through the second stage. Adjust the seat further so that there is no hissing noise and the lever has 1/8" (3.2 mm) free play when you move the tip of the lever with your finger. See photo 11.

Note: Depress the lever (19) while moving the seat with the wrench. This prevents premature indentation and wear of the seal (22).



Photo 11

5.4.25 Install the exhaust tee (13) onto the case by hooking the tee over the flat part of the flange and then working it over the rest of the flange. This operation is made much easier if the tee is immersed for one minute in hot tap water to soften it temporarily.

5.5 SET- UP OF THE SECOND STAGE

For the following adjustments, the cover and diaphragm must be removed.

5.5.1 Turn the spring adjust knob plug (29) out counter-clockwise all the way. IF the regulator is to be used as an Octopus unit, then turn the adjust knob plug (29) back in clockwise one turn.

5.5.2 Install the new O-rings (31,33) onto the hose assembly (30). Install the hose between a serviced first stage and the second stage, tighten snugly. Use two wrenches to tighten the second stage hose connection.

Note: Attach the second stage to the overhauled and properly adjusted first stage that it is going to be used with, mounted on an air tank filled to the maximum pressure the regulator is going to be used with. Install an intermediate pressure gauge into one of the low-pressure ports.

5.5.3 Carefully turn the air on. After adjusting the second stage as outlined in assembly step 5.4.24 in this manual, the lever (19) should be slightly loose against the “L” shaped foot of the shuttle valve assembly. See Photo # 9. There should be about 1/8” (3.2 mm) of free play at the end of the lever. There should be no air leaking from the second stage with proper intermediate pressure applied to the hose. If there is air leaking from anywhere on the second stage, correct the problem before going further. The best test to check for the slightest leaks is to immerse the second stage (with no cover or diaphragm installed) under pressure in water and look for bubbles indicating a leak. Correct the problem if leaks are found. See Troubleshooting section 6.1 for help.

5.5.4 Work the lever up and down a few times while the regulator is pressurized. Each time the lever is released, no air hissing should be heard.

5.6 FINAL ASSEMBLY OF THE SECOND STAGE

5.6.1 Install the diaphragm (4) into the housing (10) so that it sits evenly on the ledge.

5.6.2 Install the diaphragm cover (3) over the diaphragm. The diaphragm cover (3) is the best tool to align the diaphragm into the body. Push the cover firmly over the diaphragm so the diaphragm is seated properly.

5.6.3 Install the purge dome (2) into the cover ring (1).

5.6.4 Screw the purge dome and cover ring into housing. Adjust the purge dome in the cover ring so that the Zeagle logo sits properly when the cover ring is tightened firmly hand tight. If the Zeagle “Z” logo is not straight, it can be easily aligned using one side of the Cover Ring Removal/Alignment Tool p/n 347-1005.

5.6.5 Install the mouthpiece (12). Be sure to position the mouthpiece so that the overbite where the top teeth fit, is on the top.

5.6.6 Install the new mouthpiece tie (11) from the service kit. Position the tie lock on the side of the mouthpiece. Tighten the tie securely and cut off the excess.



! WARNING !

NEVER tighten the hose with more than 40 in. lbs. (4.5 Nm) of torque. The inlet hose fitting can be weakened by over tightening.

5.7 TESTING OF THE SECOND STAGE

A. INHALATION EFFORT:

5.7.1 With air pressure applied, turn the spring adjust plug (29) fully counter-clockwise. Move the venturi lever to the “+” position. Depress and release the purge dome. A large continuous free-flow should result. Move the venturi lever towards the “-” position. With no other intervention, by the time you get the lever 2/3 of the way to the “-” position the free-flowing should stop. This test shows the regulator is performing as it should. It is not necessary, but you can perform further inhalation tests.

5.7.2 If you have no instrumentation, breathe on the regulator to test the breathing effort. With the adjusting knob turned fully clockwise, and the venturi lever in the full “-” (pre-dive) position, the regulator will be relatively hard to inhale on but the purge dome must still purge when depressed.

5.7.3 With the spring adjust plug turned fully counter-clockwise, then one full turn in (clockwise), and the venturi lever in the full “+” (dive) position the regulator will be easy to inhale on. It is important to note that although the breathing efforts are very different in these two positions, the ultimate air delivery capacity of the regulator is essentially the same in either position.

5.7.4 If a water column or water manometer is used to check inhalation effort, it should not exceed 2” (50 mm) w. c. at cracking with the adjuster knob in the minimum effort position.

Note: These Zeagle regulators have been designed and built to perform with the “Best of the Best” in underwater breathing effort. They also have design features that were influenced by the desire to make the regulator stable. The regulator is VERY easy breathing underwater, and yet resists going into free-flow by just being bumped on the surface.

If the technician wants to lower the cracking effort to the lower end of the range, refer to the trouble shooting section of this manual (6.1)

5.7.5 Move the venturi adjusting lever (16) through its full range of movement while inhaling on the regulator. You should feel an easier inhalation effort in the “+” position than the “-” position.

B. EXHALATION EFFORT:

5.7.6 If you do not use instruments to check the exhalation effort, the flow should feel smooth and unrestricted.

5.7.7 If you use a water column, it should not exceed 1/2” w.c. (13 mm) at one atmosphere.

5.7.8 Brand new exhaust valves will sometimes adhere slightly to the case, causing a slight increase in exhalation effort. This condition will disappear with use.

C. LEAK TEST:

5.7.9 Disconnect the air supply. Purge the regulator of all positive air pressure.

5.7.10 Slowly immerse the second stage in a pan of water with the mouthpiece pointing straight up.

5.7.11 Immerse the regulator until the water is 1/4" to 1/8" (.64 to .32 cm) from the lip of the mouthpiece.

5.7.12 Hold the regulator in this position for one minute and then slowly raise it out of the water.

5.7.13 Tip the regulator mouthpiece downward and watch the inside of the mouthpiece tube. If any water escapes from the mouthpiece tube, check for the source of the leakage.

D. INTERMEDIATE PRESSURE AIR LEAKS:

5.7.14 Attach the regulator first stage to a tank short enough to totally submerge the first and second stage in your filling station cooling water. Adjust the breathing effort adjustment plug to the minimum breathing effort position.

5.7.15 With the tank valve still turned off, flood the second stage completely with water, and then position it mouthpiece up.

5.7.16 Turn the tank air valve on slowly and then watch for any leaks in the first or second stage. If leaks are seen coming from the second stage, repeat the test with the cover assembly removed. You will be able to see more clearly exactly where the leak is coming from.

5.7.17 Repair any leaks.

6.0 HELPFUL HINTS

6.1 TROUBLESHOOTING

POSSIBLE CAUSE

RECOMMENDED ACTION

POSSIBLE CAUSE	RECOMMENDED ACTION
Inlet filter clogged.	Replace the filter.
Air supply to 1st stage insufficient.	Verify the supply air pressure. Make sure the customer had the air valve turned all the way on during the dive.
1st or 2nd stage improperly adjusted.	Refer to sections 4.5 and 5.5 of this manual.

A. HIGH INHALATION EFFORT AT SURFACE (cracking effort in air):

POSSIBLE CAUSE

RECOMMENDED ACTION

1st or 2nd Stage adjusted improperly	Refer to sections 4.5 and 5.5 of this manual.
2nd stage spring force on high end of range	<p>The spring (25) can be conditioned to a lower thrust. This is done by squeezing it down (with a vise or fingers) to near solid height (.350") where the space between the coils is the same as the thickness of the spring wire. Do not squeeze the spring coils completely closed as this will result in too low a cracking effort.</p> <p>Note: This will lower the cracking effort in air, but will have little or no effect on the underwater performance. It is usually not necessary and should only be done if the customer understands that a low cracking effort makes a regulator more prone to hissing and will probably need more frequent adjusting. If the spring is over squeezed during this conditioning, so that the coils touch each other, the 2nd stage may hiss when the adjust plug (29) is turned all of the way out. Turning the plug in (clockwise) slightly will stop the hissing if this is the case. If the hissing does not stop, the seat (18) needs adjusting, or the seal (22) needs replacing.</p>

B. CREEPING INTERMEDIATE PRESSURE:

POSSIBLE CAUSE

RECOMMENDED ACTION

Damaged or worn 1st stage seat (6).	Replace seat
Nick in sealing surface of Body Orifice (14)	Replace Body or Buff out Scratch
Seat (6) has not taken shape of Orifice yet.	Let the Regulator sit with the pressure on for a few minutes and measure pressure again.

C. HISSING FROM SECOND STAGE (but intermediate pressure is OK):

POSSIBLE CAUSE

RECOMMENDED ACTION

Damaged or worn 2nd stage seating seal (22)	Replace seating seal
Nicked seat (18) sealing surfaces	Replace seat
2nd stage demand lever (19) bent too high	Replace lever
Worn O-ring (24) on piston (23)	Replace O-ring
Damaged O-ring groove on piston (23)	Replace piston
Worn O-ring (17) on seat (18)	Replace O-ring
Worn O-ring groove on seat (18)	Replace seat
Seat (18) out of adjustment	Adjust Seat

C. WET BREATHING:

POSSIBLE CAUSE	RECOMMENDED ACTION
Diaphragm improperly installed or hole in diaphragm	Check position of diaphragm visually. Replace if holes found by holding up to a light.
Damaged or loose fitting exhaust valve	Replace exhaust valve (14)
Crack in housing (10)	Replace housing
Worn venturi lever O-rings (15, 27)	Replace O-rings (15, 27)
Scratched or worn venturi lever sealing surfaces	Replace venturi lever (16)
Scratched or worn housing (10) sealing surfaces	Replace housing
Improper clearing techniques by diver	Instruct diver on clearing techniques
Extremely slow breathing allowing water to build up in housing rather than being blown out	Explain this result of slow breathing to diver.

D. HIGH FREQUENCY HUMMING OR BUZZING DURING INHALATION:

POSSIBLE CAUSE	RECOMMENDED ACTION
Harmonic resonance between the springs and other 1st stage components.	Remove the main spring (7) flip it over and re-install.
“ “	Replace spring or other components until resonance stops.

E. LOW FREQUENCY FLUTTERING DURING INHALATION (Above the surface only):

POSSIBLE CAUSE	RECOMMENDED ACTION
Harmonic resonance between the springs and other 2nd stage components.	Remove, rotate and re-install diaphragm or switch diaphragm with another.
“ “	Replace seating seal (22)
“ “	Remove, rotate and re-install spring (25)
“ “	Explain to the customer that this is not harmful to the regulator, and does not happen underwater.
“ “	Move venturi lever (16) towards “-” position until harmonic resonance stops.

6.2 PARTS CLEANING RECOMMENDATIONS

6.2.1 Regulators that see heavy use, particularly those used in salt water, often require extra effort to remove dirt and corrosion from the parts of the regulator. Some suggested cleaning solutions are listed at the end of this section, and there are probably many others being used successfully. The following are a few general suggestions we can make.

6.2.2 Don't expect your cleaning solution to do all the work in a matter of seconds. If the solution cleans extremely rapidly, it is probably too strong and is etching the finish on the parts. Use a wooden or plastic stick or a soft bristle brush to help get rid of the thickest deposits. Take special care not to damage orifice sealing areas.

6.2.3 Soft parts absorb ultrasonic energy. Remove all O-rings and seals from metal parts before cleaning them. If possible, do not clean plastic parts with the metal parts, or at least understand that every plastic part you put into the ultrasonic cleaner is slowing down the ultrasonic cleaning process for the rest of the parts.

6.3 COMMONLY USED CLEANING SOLUTIONS

SOLUTION	COMMENTS
Hot Soapy water	Preferable. Good for plastic, silicone and plated metal parts.
Vinegar and water (equal part solution) (weaker solution in Ultrasonic Cleaner)	Ingredients easily available. Approx. 15 min. cleaning time. May damage chrome finish. Never use on plastic parts. Vinegar dissolves the plastics in most polymers making them brittle and more prone to breakage.
Simple Green® and Water	Simple Green® is a readily available degreaser. Read the product label for mixing ratios with water.
Cleaning solutions recommended by ultrasonic cleaner manufacturers	The preferred choice. Check with the manufacturer for strengths and recommended uses for their cleaners. Choose soap solutions over acidic ones.

6.4 HANDLING TIPS

How your customers treat their regulators will directly influence the unit's function and durability. Following are a few tips that you can pass on to your customers to help assure the durability of their Zeagle Scuba Regulator.

A. PRE-DIVE CHECKS:

6.4.1 Check the hoses and hose connections for cuts, abrasions or other signs of damage before mounting the regulator on the tank valve. Slide the hose protectors back to inspect the areas of the hose normally covered. Be sure all hose connections are tight.

6.4.2 Just before mounting the regulator on the valve, always turn the valve on briefly to blow any trapped water out of the valve. There is often salty water trapped in the outlet side of the valve. This entrapped salt water being blown through the interior of the regulator is the number one source of internal corrosion and problems with Scuba regulators.

6.4.3 Before turning on the tank air valve, check to make sure that the yoke nut or DIN connection is tight and the regulator body is aligned properly, with no kinks in the hoses.

6.4.4 Turn the tank valve on slowly and listen for leaks. If any leaks are found, replace or repair parts as recommended.

6.4.5 Never lift the tank/BCD assembly by the regulator or hoses.

6.4.6 Surface-test the regulator by breathing lightly through the mouthpiece. Depressing the purge button above the water's surface is not an effective or thorough method for testing the function of the regulator.

B. POST-DIVE CARE:

6.4.7 After the dive, blow all water out of the dust cap with clean dry air or dab the water out with an absorbent cloth and place the cap securely on the regulator inlet. On multiple tank dives, use great care to keep salt water out of the regulator inlet when tanks are changed. Neglecting these simple procedures is another great cause of corrosion and wear in Scuba regulators. Zeagle's Dry Seal System keeps all other water-borne contamination out of the first stage body.

6.4.8 With the dust cap securely in place, rinse the first and second stages in clean fresh water. DO NOT depress the purge button before or during rinsing since this may introduce water into the second stage and the low-pressure hose. Shake or blow all excess water from the second stage and allow the entire regulator to air-dry before storing.

6.4.9 Store regulator in a clean bag or storage box, away from sunlight, excessive heat and humidity.

7.0 WARRANTY AND MAINTENANCE INFORMATION

7.1 PROPER PROCEDURE FOR SERVICE PAPERWORK (USA)

7.1.1 Make sure your service location has an adequate supply of the three part "Zeagle Service Order / Parts Request" forms. One of these carbon-paper forms is required to get credit for parts used in any warranty replacement. Contact Zeagle Customer Service for replacement forms.

7.1.2 When the regulator is received from the customer for servicing, verify that they are the original retail owner of the regulator and that they have had the regulator serviced annually at an Authorized Zeagle Dealer. You can use your records for this, or receipts they have. If they are not the original owner or have not had the regulator serviced annually, the warranty is no longer in effect.

7.1.3 Fill out the Zeagle Service Order / Parts Request form. **PRINT CLEARLY!** If you use service kits, you only have to use the service kit part number(s) to represent all of the parts in that kit. Parts other than those in the kits have to be listed individually. The reason for replacing the part also has to be listed on the form.

7.1.4 Attach all of the old parts that were replaced under warranty in a plastic bag and attach it to the Zeagle Service Order / Parts Request form.

7.1.5 If a body or housing is replaced, the replacement parts will have different new serial numbers. Note the new serial # in "Description of Part" section of the Zeagle Service Order / Parts Request form. Write the old number in the Serial # section. The dive store and the customer should keep records of this serial number change. Use the new numbers in future warranty claims.

7.1.6 Contact Zeagle Customer Service and ask for an RA (Return Authorization) number for each group of Zeagle Service Order / Parts Request forms you are going to send in. **YOU MUST GET A RA# BEFORE RETURNING ANY PARTS TO ZEAGLE.** Due to high volume and a desire to move promised items through the service department quickly, boxes arriving without a RA# will be put at the end of the line and will be opened when all other work on properly RA numbered items is finished. This could delay your items by weeks during peak season!

7.1.7 Write the RA number on the Zeagle Service Order / Parts Request form. Mail the forms with attached parts bags to Zeagle. You will receive credit or replacement parts **ONLY** if an RA number is printed on the form.

7.1.8 If you are servicing Zeagle regulators outside of the United States, your return procedures may be different. Check with your regional Zeagle Distributor for details.

7.2 SCHEDULED MAINTENANCE

7.2.1 To keep the owner warranty in effect, your customers must have their regulators inspected and serviced annually (within six weeks before or after the anniversary of the date of purchase) by an authorized Zeagle Dealer. Failure to do so invalidates the warranty.

7.2.2 Even with infrequent use, the regulator should be serviced annually to ensure proper performance and satisfy warranty requirements.

7.2.3 After calling Zeagle Customer Service at (813) 782-5568 for an RA number, Zeagle Scuba parts and warranty forms are sent to the following address:

RA # (fill your RA # in here)
37150 Chancey Road
Zephyrhills, Florida 33541
U. S. A.

7.3 Order Form (sample)

This is a copy of the Service Parts Request Form. The actual form is a three-page carbon copy that is available by request from Zeagle Customer Service. If you do not have any forms on hand, you may photocopy this page and use it to receive warranty parts credit.

Service Order / Parts Request Form



This form must be used by the Service Center
for ANY Warranty Servicing

You MUST contact Zeagle for an RA
Number to receive any Warranty Credit

37150 Chancey Rd.
Zephyrhills, FL 33541
(813) 782-5568
Fax (813) 782-5569
www.zeagle.com

Zeagle Service Center: City, State (Prov), Country: Phone / E-mail:			
Date Serviced:		Technician Name (PRINT): Technician Number:	
Customer Name: Address: City, State (Prov), Country: Phone / E-mail:			
RA # (call Zeagle): _____			
1st Stage Model: _____		Serial #: _____	
2nd Stage Model: _____		Serial #: _____	
Octopus Model: _____		Serial #: _____	
Comments:			
Part # Installed	Description of Part	Warranty Item? Y/N	Customer Price
345-1000	First Stage Service Kit		
345-2000	Second Stage Service Kit		
Note: If a body or housing is replaced, note the new serial # in "Description of Part"			Total:

I am the original (first) owner of this equipment being serviced. Yes ____ No ____

Customer's Signature: _____ Date: _____

The customer must provide proof of original ownership (receipts, etc.) before any "in Warranty" service can be performed.
Service Center: Be sure this form is completely filled out, signed by the customer and returned to Zeagle for credit parts.

2nd Stage O- Rings (included in Kit) # 345-2000

160-9532-N7 (24) for piston (23) to balancing cylinder (26)



160-0010-N7 (17, 33) for seat (orifice) (18) & hose (30) outlet end



160-0011-N7 (28, 31) for spring adjuster (29) & hose (30) inlet end



160-0015-N7 (9, 27) for valve tube (21) at venturi lever & heat sink (8)

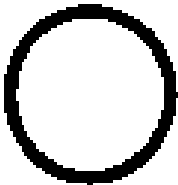

160-0019-N7 (15) outside of venturi control lever (16)

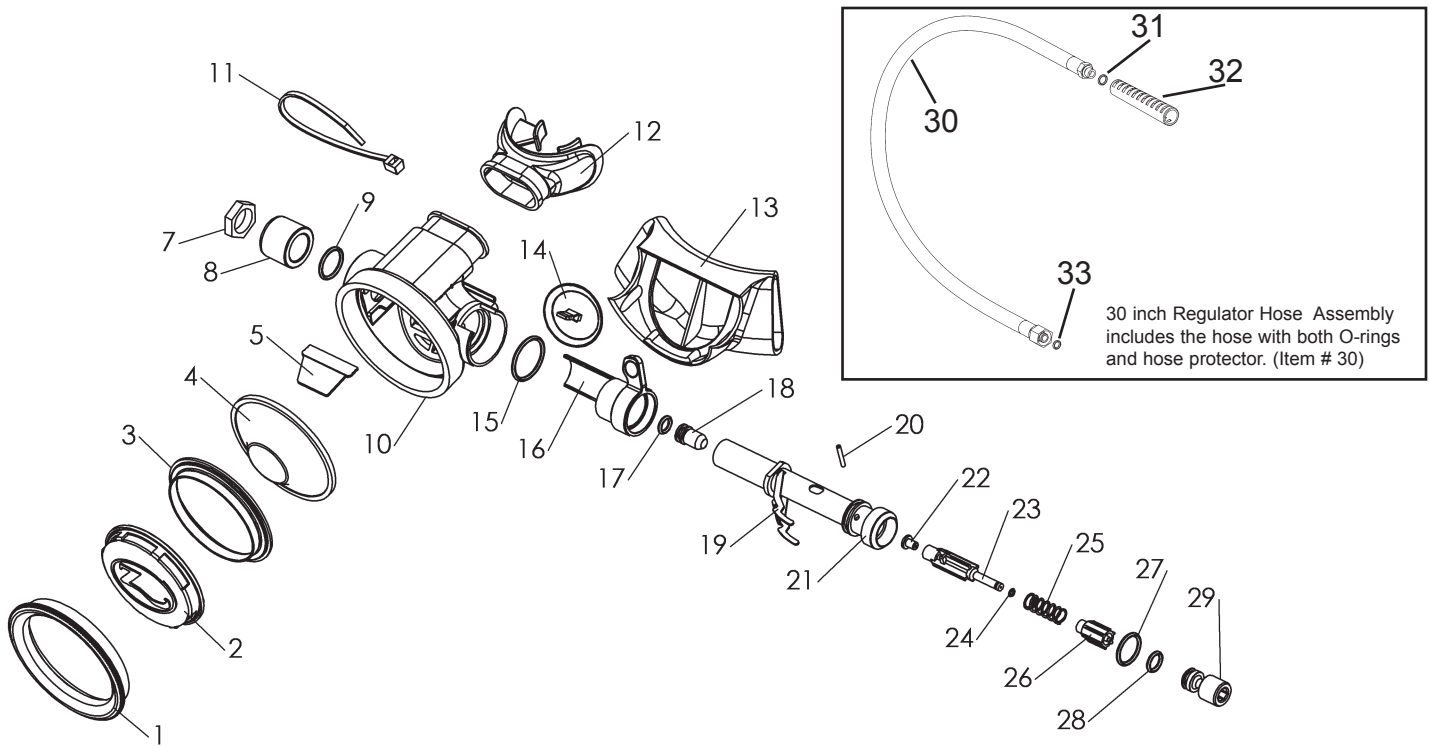

SECOND STAGE REGULATOR

The letter at the beginning of the serial number on the second stage indicates the model of that second stage. If the serial number begins with "J" (e.g. J001324) it is an Envoy second stage with venturi control. For further information, contact Zeagle.

ITEM #	PART #	DESCRIPTION.....
1	342-0210-KA	Cover Ring
2	342-0209-LG	Purge Dome, GRAY (standard color)
2	342-0209-LY	Purge Dome, YELLOW (octopus color)
2	342-0209-LK	Purge Dome, BLACK
3	342-0208-KA	Diaphragm Cover
4	342-0207-AA	Diaphragm
5	342-0225-KA	Deflector
7	342-0221-CD	Nut
8	342-0222-SA	Bushing
9*	160-0015-N7	O-ring (bushing to housing)
10	342-0201-KA	Housing
11*	111-4002	Tie Wrap (2 needed)
12	342-0216-MU	Mouthpiece
13	342-0217-LA	Exhaust Tee
14	342-0218-MA	Exhaust Valve
15*	160-0019-N7	O-ring (control lever to housing)
16	342-0203-KA	Venturi Control Lever
17*	160-0010-N7	O-ring (for seat)
18	342-0212-HB	Seat (orifice)
19	342-0206-WH	Lever
20	342-0228-UA	Pin
21	342-0202-CD	Valve Tube
22*	342-0213-MB	Seating Seal
23	342-0214-HA	Piston
24*	160-9532-N7	O-ring (for piston)
25	342-0220-VH	Spring
26	342-0215-HA	Balancing Cylinder
27*	160-0015-N7	O-ring (for valve tube)
28*	160-0011-N7	O-ring (for spring adjuster)
29	342-0230-SA	Spring Adjust Plug
30	165-1034	30" Hose Assembly (other lengths available)
31*	160-0011-N7	O-ring (hose inlet end)
32	342-0229-LA	Hose Protector
33*	160-0010-N7	O-ring (hose outlet end)
34	342-0222-SA	Plastic Bushing (replaces Heat Sink {8} in some models)
35	342-0230-SA	Plastic Spring Adjuster Plug (replaces the Spring Adjust Knob Assembly {29} in some models)

* An asterisk next to the Item Number means that part is included in the Standard Service Kit.
The Service Kit Part # for the 1st Stage is 345-1000. The 2nd Stage Service Kit Part # is 345-2000.

RaZor Filling Whip Parts

ITEM #	PART #	DESCRIPTION.....
1	331-FA01-CD	Filler Handwheel
2*	160-0003-N9	O-Ring (for Swivel)
3	331-FA03-CD	Spool (spud)
4*	160-0003-N9	O-Ring (for Swivel)
5	331-FA05-AA	Swivel Assembly
6	331-FA06-WA	Cir-Clip
7	331-FA07-CD	Purge Collar
8	331-FA08-CD	Body
9	331-FA09-AA	Gauge (5000 psi)
10	165-1063	Hose 48" (5000 psi with 1/4" Male NPT ends)
11*	331-FA11-SA	Purge Valve
12*	341-FB24-CA	Valve Plug Assembly
13	341-FB25-CD	Stem
14*	341-FB26-GA	Teflon Washer
15*	160-0012-N9	O-Ring (for bonnet nut)
16	341-FB27-CD	Bonnet Nut
17	341-FB28-GA	Nylon Washer
18	341-FB29-CL	Handwheel (for Valve)
19	341-FB30-VH	Spring (for Handwheel)
20	341-FB31-CD	Stem Nut
21	330-6014-AA	Yoke Assembly for Filling Whip
22	331-FA12-WA	Quick-Disconnect (female)
23	331-FA35-SA	Washer, Nylon

Filling Whip Assembly
includes
48" Hose with Yoke: 330-6048-AA
See the Service Procedure
Beginning on page 32

* An asterisk next to the Item Number means that part is included in the Standard Service Kit. The Service Kit Part # for the Filling Whip Assembly is 345-1002.

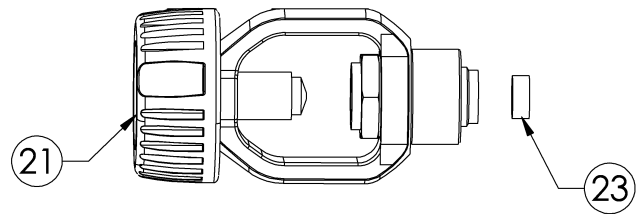
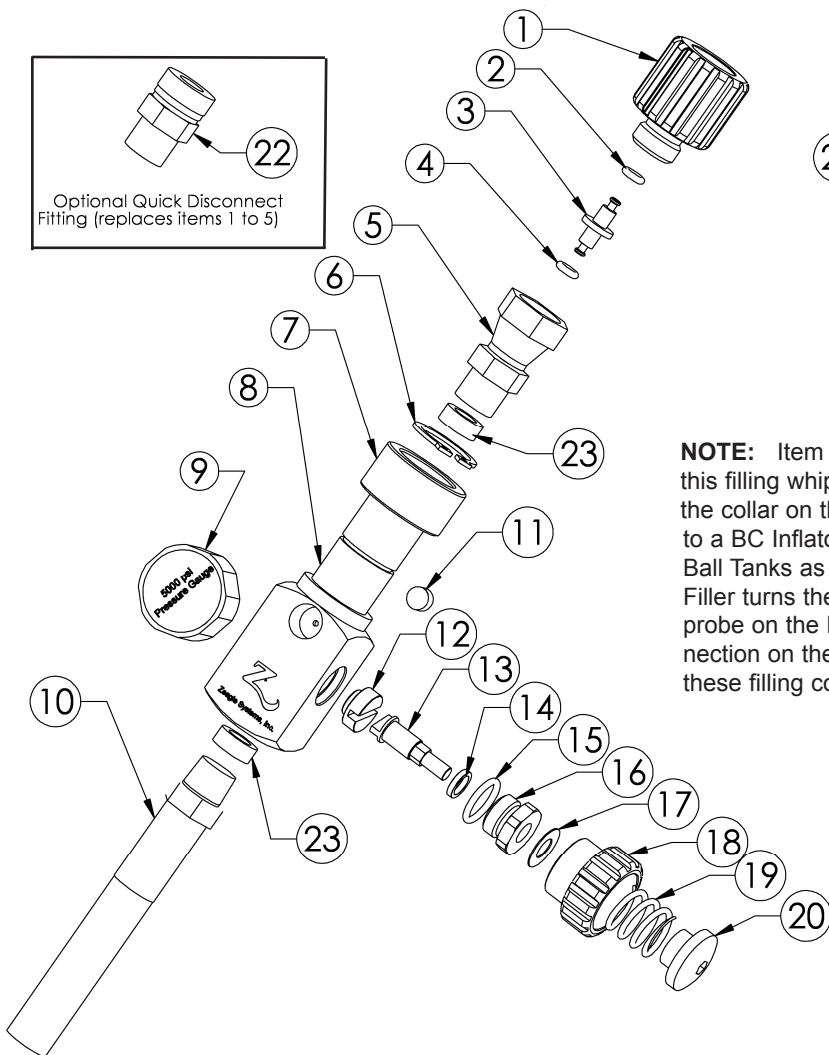

NOTE: Item 22 is an optional "Quick-Disconnect" method for using this filling whip. When this QD Fitting is used, the operator pulls back the collar on the QD fitting to make and release the connection similar to a BC Inflator Hose connection. Item 22 is often used to fill Paint-Ball Tanks as well. When items 1, 2, 3, 4 and 5 are installed, the Filler turns the handwheel (item 1) on or off of the threads of the filling probe on the RaZor regulator to make the connection. The male connection on the Razor regulator is designed to work with either one of these filling connections.

IMPORTANT: The 48" hose filling assembly can be used as a permanent filling station whip, by disconnecting the Yoke (Item 21) and then screwing the 1/4" male NPT end of the hose into the filling station plumbing.

8.0 SERVICE PROCEDURES FOR THE ZEAGLE RaZor, Filler Valve and Whip

8.0.1 Before you begin disassembly of the regulator, test the Filler Whip and Hose for smoothness of operation and leakage. Pre-testing in this way will help the technician to pinpoint any specific problems requiring repair.

8.0.2 The work area must be clean and well lighted, with clean compressed air available to blow sand and dirt from parts. You'll need a sturdy vise bolted to a secure workbench.

8.1 TOOLS & ITEMS REQUIRED FOR RaZor Filler Whip SERVICING

- 5/32" Allen wrench (p/n 347-0532)
- Cir-Clip Pliers
- 6" or 8" good quality adjustable wrenches for hose connections.
- Annual Service Kit p/n 345-1003
- Clean Shop Rags
- LTI Christo-Lube 111® (p/n 347-.0111), or Dow-Corning 111® Silicone Grease
- The Service Video for this Filler Valve is included in the RaZor Regulator Service Video VHS Tape (p/n 347-0103) or Service CD ROM (p/n 347-0103C) or DVD (p/n 347-0103D)

8.2 DISASSEMBLY OF THE FILLER VALVE FOR OVERHAUL

To view all of the parts used in the RaZor first stage, look at the page before this one in this manual. The bracketed numbers in the text refer to the corresponding circled item numbers on the exploded view drawing.

NOTE: Your Filler Valve may be equipped with the Screw on threaded connection (1,2,3,4,5) or the High Pressure Quick-Disconnect (22). Adjust your service procedure accordingly.

8.2.1 Inspect the filler hose (10) carefully. Look for any cracks, cuts or severe abrasions. Replace if necessary.

8.2.2 Use two wrenches, or a vise and wrench to remove the valve assembly from the hose. Unless it is damaged or leaking, leave the Nylon Washer (23) in the Valve Body (8) during the entire overhaul.

8.2.3 Position the valve assembly in a vise, clamping it by the body. Remove the gauge (9) from the valve body with a 6" or 8" adjustable wrench.

8.2.4 If your filler valve has a Quick Disconnect Fitting (22), remove it from the valve body with a wrench. It is not practical to remove or replace the small ball bearings from the QD fitting. If they are worn or missing, the entire QD Fitting (22) is replaced. The O-ring in the end of the QD Fitting is removed by piercing it with a pin and flipping it out. Discard the O-ring. Go to step 8.2.8 below. Unless it is damaged or leaking, leave the Nylon Washer (23) in the Valve Body (8) during the entire overhaul.

8.2.5 If your filler valve has a Threaded Handwheel Fitting, remove the filler handwheel (1) from the Swivel Assembly (5) with a wrench.

8.2.6 Remove the spool (3) from the swivel assembly (5). Remove the O-rings (2,4) from the spool using a sharp pin or pick to pierce the O-ring and flip it off of the spool. Take care not to scratch the O-ring sealing surface on the spool as you remove the O-rings.

8.2.7 If it is in good shape, the swivel assembly (5) can be left in the body. If it is going to be changed, remove it from the valve body (8) at this time.

8.2.8 Use expanding Cir-Clip pliers to remove the Cir-Clip (6) from the body.

8.2.9 Remove the purge collar (7) from the body. Place a mark on the bottom edge of the collar to remind you which way the collar will go back on during assembly.

8.2.10 Remove and discard the nylon purge valve (11).

8.2.11 Turn the handwheel (18) halfway between fully opened and fully closed to position the valve plug assembly loosely.

8.2.12 Use a 5/32" Allen wrench to remove the stem nut, spring, handwheel and nylon washer (20, 19, 18, 17) from the valve stem (13).

8.2.13 Use a small adjustable wrench to remove the bonnet nut (16) from the body.

8.2.14 Remove the stem (13) from the bonnet nut.

8.2.14 Remove and discard the Teflon washer (14) and the O-ring (15) from the bonnet nut (16).

8.2.15 Use the stem (13) to turn the valve plug assembly (that you loosened in step 8.2.11) completely out of the body. Discard the plug assembly.

8.2.16 Put all metal parts (except the gauge 9) that need cleaning into an ultra-sonic cleaner. Refer to section 6.2 for cleaning recommendations. Rinse the parts in fresh water and blow them dry for inspection.

8.3 INSPECTION OF THE FILLER VALVE FOR OVERHAUL

8.3.1 If the filler valve was passing air even when the handwheel was firmly shut, look closely at the cone shaped orifice where the valve plug assembly was removed from. If any significant nicks are seen on the sealing surface of the orifice, then the body (8) will have to be replaced.

8.3.2 Inspect the entire length of the filler hose for nicks, cuts, bubbles (blisters) under the surface of the outer plastic layer. Pay particular attention to the area at the metal crimping ferrules at each end as this is where hoses tend to fail first. Replace the hose if any defects are seen.

8.4 ASSEMBLY OF THE FILLER VALVE AFTER INSPECTION

8.4.1 Open the service parts kit # 345-1003.

8.4.2 Lubricate the threads lightly and install the new valve plug assembly into the body. Use the stem (13) to turn the valve plug assembly until it reaches the bottom of the threads.

8.4.3 Lightly lubricate the O-ring (15) and install it on the bonnet nut (16).

8.4.4 Lightly lubricate the Teflon washer (13) and install it onto the stem (13).

8.4.5 Install the stem (13) into the bonnet nut (16).

8.4.6 Install the bonnet nut and stem assembly into the body. Take care to engage the stem's tang into the slot in the plug assembly (12) as the bonnet nut is tightened. Failure to engage the stem tang into the slot can cause the tang to break as the bonnet nut is tightened.

8.4.7 Tighten the bonnet nut (16) snugly with 1-2 ft. lbs. (2-3 Nm) of torque.

8.4.8 Place the original nylon washer, handwheel, spring and stem nut (17, 18, 19, 20) onto the stem (13).

8.4.9 Tighten the stem nut into the handwheel until the outer edge of the stem nut is even with the edge of the handwheel.

8.4.10 Insert the nylon purge valve (11) into the body, pointed end first.

8.4.11 Install the purge collar over the body and purge valve. Note the mark you put on the edge of the collar as per step 8.2.9 so that the purge collar is installed the right way around.

8.4.12 Use Cir-Clip pliers to install the Cir-Clip (6) into its groove on the body.

A NOTE ON TEFLON TAPE: If using Teflon tape, always take special care not to get tape on the first (outside) thread. Any tape that gets on this thread or on the inner face of the thread body will be cut off when the thread is tightened. Loose tape will then probably get tangled in the internal valving causing leaks.

8.4.13 If the stainless steel Quick Disconnect fitting (22) is used on your filler valve. Install the new face-seal O-ring from the kit into the QD fitting. Put pipe sealant or Teflon tape on the male threads of the QD fitting. Tighten the QD fitting (22) into the body (8). Go to step 8.4.15.

8.4.14 If the threaded connection (1, 2, 3, 4, 5) is used, put pipe sealant or Teflon tape onto the male threads of the swivel (5) and install it tightly into the body (8). Generously lubricate the spool with its O-rings installed (2, 3, 4) and install it into the swivel (5). Thread the filler handwheel (1) into the swivel and tighten it snugly with an adjustable wrench on the swivel's nut.

8.4.15 Put pipe sealant or Teflon tape onto the male threads of the gauge (9). Use an adjustable wrench on the flats of the gauge to tighten it.

8.4.16 Put pipe sealant or Teflon tape onto the male threads of the hose (10). Use two wrenches to tighten the hose into the body.

8.4.17 If the filler whip is part of a fill station manifold, put pipe sealant or Teflon tape onto the male threads of the hose and install it into the fill station manifold. If the filler whip is used to fill the RaZor regulator from another scuba tank, install the male threads of the hose into the yoke assembly for the filling whip (21).

8.4.18 Pressurize and test the system for leaks. Correct any leaks found.



37150 Chancey Road
Zephyrhills, Florida 33541
U. S. A.

Zeagle Scuba, the Zeagle symbol, RaZor, ReZort, ZX, Envoy, 50D, DS-V and Flathead VI are trademarks of Zeagle Systems Inc. All other names are trademarks of their respective owners. All products subject to change without notice.

Zeagle Web Site www.zeagle.com
E-mail all technical questions to Zeagle at tech@zeagle.com
Phone (813) 872-5568, Fax (813) 782-5569

© 2002 - 2007 Zeagle Systems Inc.
Printed in USA

The Part Number for this Manual is 347-3005

Rev. A

zeagle®
SYSTEMS, INC.